

# EPHRAIM MOGALE LOCAL MUNICIPALITY



**QUOTATION NO: 8/3/228**

**PROJECT DESCRIPTION: SUPPLY AND DELIVERY OF ELECTRICAL AND RELATED MAINTENANCE MATERIAL**

**PREPARED FOR AND BY**

**THE MUNICIPAL MANAGER**

**EPHRAIM MOGALE LOCAL MUNICIPALITY**

Private Bag x 111

**MARBLE HALL**

0450

Tel: (013) 261 8400

Fax: (013) 261 2985

**Name of Bidder** : \_\_\_\_\_

**CSD Supplier No** : \_\_\_\_\_

**Total Bid Price** : \_\_\_\_\_

## **SUBMISSION DETAILS**

### **TENDER BOX:**

EPHRAIM MOGALE LOCAL MUNICIPALITY  
2 FICUS STREET (ENTRANCE TO FINANCE AND  
TECHNICAL BUILDING)  
MARBLE HALL, 0450 (LIMPOPO)

### **CLOSING DATE AND TIME:**

**Thursday, 08 September 2016 @ 12H00**

Quote: 8/3/228

# EPHRAIM MOGALE LOCAL MUNICIPALITY

QUOTATION NO: 8/3/228

## PROJECT DESCRIPTION: SUPPLY AND DELIVERY OF ELECTRICAL AND RELATED MAINTENANCE MATERIAL

Ephraim Mogale Local Municipality hereby invites quotations from suitably qualified and interested service providers for the Supply and Delivery of Electrical and Related Maintenance Material

Quotations may only be submitted on the quotation document issued. The quotation document will be available at the Supply Chain Management Unit of the Ephraim Mogale Local Municipality and on the Municipal website [www.ephraimmogalelm.gov.za](http://www.ephraimmogalelm.gov.za).

Quotations must be in writing and must clearly indicate the relevant supply or service for which is being quoted and be submitted in a sealed envelope be dropped in the tender box as indicated on the cover page. Late or unmarked quotations will not be considered. **Bids transmitted by fax or e-mail will not be accepted**, although Ephraim Mogale Local Municipality accepts no responsibility for ensuring that quotations are timeously received by Ephraim Mogale Local Municipality.

Quotations will not be considered unless the following information has been furnished:

- i. Proof of registration with the Central Supplier Database with an active “MAAA” number;
- ii. Copy of Tax Clearance Certificate and PIN to verify status issued by SARS;
- iii. VAT registration number, if any;
- iv. Proof of Municipal Rates & Taxes for the company or the directors accounts not older than 3 (three) months or valid lease agreement in case of company renting along with service account billed in the name of the bidder or letter from tribal authority accompanied by confirmation from municipality that services are not levied/charged.
- v. If a natural person, whether he or she is or not in the service of the state, or has been in the service of the state in the previous twelve months; or
- vi. if not a natural person, whether any of its directors, managers, principal shareholders or stakeholders is in the service of the state, or has been in the service of the state in the previous twelve months; or
- vii. Whether a spouse, child or parent of the provider or of a director, manager, shareholder or stakeholder referred to in (vi) is in the service of the state, or has been in the service of the state in the previous twelve months.
- viii. Fully completed and signed municipal bidding documents (**MBD4, MBD6.1, MBD8, MBD9, MBD6.2**)  
Your quotation will be rejected if the above forms are not fully completed, signed and submitted.

### Evaluation of Quotations

Notice is drawn to the fact that the awarding of this quotation will be in terms of the Supply Chain Management Policy of the Ephraim Mogale Local Municipality and prescribed evaluation criteria in terms of the Municipal Supply Chain Management Regulations, 2005.

Quote: 8/3/228

### Evaluation points

Preference points for this bid shall be awarded for:

- (a) Price; and
- (b) B-BBEE Status Level of Contribution.

The maximum points for this quotation are allocated as follows:

	<b>Points</b>
Price	80
B-BBEE Status Level of Contribution.	20
<b>Total points for price and BBEEE</b>	<b>100</b>

For bidders to claim points for BBEE status level of contribution, bidders are required to submit original and valid B-BBEE Status Level Verification Certificates or certified copies thereof or the sworn affidavit to substantiate their B-BBEE rating claim. Failure to submit such a certificate will result in a bidder not qualifying for preference points for B-BBEE.

**Points will be awarded to a bidder for attaining the B-BBEE status level of the contributor**

<b>B-BBEE Status Level of Contributors (System)</b>	<b>Number of points (80 - 20)</b>
1.	20
2.	18
3.	16
4.	12
5.	8
6.	6
7.	4
8.	2
<b>Non-compliance Contributor</b>	<b>0</b>

### Pricing and Validity

The pricing of the quotation should be in South African Rands (ZAR) and be valid for 90 days from the closing date

For any administrative enquiries you can contact the Supply Chain Management Unit at 013 261 8450/8462/8496 and any technical enquiries with the Manager Electrical Services at 013 261 8454

**MATHEBELA MM**  
**MUNICIPAL MANAGER**

Quote: 8/3/228

# EPHRAIM MOGALE LOCAL MUNICIPALITY

QUOTATION NO: 8/3/228

**PROJECT DESCRIPTION: SUPPLY AND DELIVERY OF ELECTRICAL AND RELATED MAINTENANCE MATERIAL**

---

**DETAILED SPECIFICATION - ALL ELECTRICAL MATERIAL MUST BE SABS APPROVED**

No	DESCRIPTION	UNIT	QTY
1	Batteries, rechargeable, for substation as specified in Addendum A	Sum	1
2	Batteries, rechargeable, for substation as specified in Addendum B	Sum	1
3	Keyed alike locks as specified in Addendum C	Sum	1
4	Insulation oil for transformers. SABS 555. In 20liter drums or cans	No	10
5	Droppers, T-type, Steel, 1250mm	No	300
6	Cable Joint, Heat shrink, Inline, including Earthing Modules for: 70mm <sup>2</sup> , 3 Core, 11KV, PILC, PVC, Steel Wire Armed Cable.	No	4
7	Termination, Heat shrink, Outdoor, including Earthing Modules for: 70mm <sup>2</sup> , 3 Core, 11KV, PILC, PVC, Steel Wire Armoured Cable.	No	4
8	Boot, Heat shrink, Right angle, for 70mm <sup>2</sup> x 3-Core x 11kv PILC Cable	Sets of 3	6
9	Cable Joint, resin cast, 3M 91A2 (for 25mm <sup>2</sup> x 4 core armoured cable, PVC, SWA,PVC)	No	4
10	Cable Joint, resin cast, 3M 91A3(for 50mm <sup>2</sup> x 4 core armoured cable, PVC, SWA, PVC)	No	2
11	Cable Joint, resin cast, 3M 91A4(for 95mm <sup>2</sup> x 4 core armoured cable, PVC, SWA, PVC)	No	2
12	Cable Joint, resin cast, 3M 91A5(for 150mm <sup>2</sup> x 4 core armoured cable, PVC, SWA, PVC)	No	2
13	Self-amalgamating insulation tape, 19mm x 9meter	No	10
14	Electrical insulation putty-tape, thickness 3.175mm, 38mm wide and 1.5meter long	No	9
15	Wheel barrow, Heavy Duty, SABS approved, steel, for construction	No	3
16	Shovel, SABS, steel shaft	No	3
17	Pick, 3kg, (keel pickaxe)	No	3
18	Pick Handle, PVC	No	3

Quote: 8/3/228

19	Rakes, steel, with steel shaft	No	3
20	Cable sleeve, 110mmØ, PVC	Meter	60
21	Insulation tape, PVC, Nitto type: 5 x red, 5 x white, 5 x blue, 5 x black	No	20
22	MC Circuit breaker, 1000A, 415Volt, 65kA, 3 phase, Thermal & Magnetic, complete with bus bars sections in supply and load side with two holes for connections per bus bar. (similar to CBi N65D)	No	1
23	Cable, flexible, 95mm <sup>2</sup> , annealed stranded copper, PVC insulated, 600v/1000V, 70°C, according to SANS 1507-3	Meter	15
24	Cable ties, T50R, black(packs of 100)	pack	20
25	Cable ties, T50I, black (packs of 100)	pack	20
26	"Q" Clamp 26	No	10
27	"Q" Clamp 32	No	10
28	"Q" Clamp 40	No	10
29	"Q" Clamp 46	No	10
30	"Q" Clamp 52	No	10
31	Rawl Bolts/Anchor Bolts, 6mmØ X 60mm	No	20
32	Ferrules 16mm <sup>2</sup>	No	100
33	Ferrules 35mm <sup>2</sup>	No	100
34	Ferrules 50mm <sup>2</sup>	No	100
35	Ferrules 70mm <sup>2</sup>	No	100
36	Ferrules 95mm <sup>2</sup>	No	100
37	Lugs 95mm <sup>2</sup> x 12mmØ	No	100
38	Lugs 16mm <sup>2</sup> x 8mmØ	No	100
39	Lugs 35mm <sup>2</sup> x 10mmØ	No	100
40	Lugs 50mm <sup>2</sup> x 10mmØ	No	100
41	Lugs 70mm <sup>2</sup> x 12mmØ	No	100
42	Lugs 95mm <sup>2</sup> x 12mmØ	No	100

Quote: 8/3/228

## ADDENDUM A

### RECHARGEABLE BATTERIES FOR INDUSTRIAL SUBSTATION

The batteries should be compatible for use with an Aztec Electronics, Type TAYR, 110/220Volt, 4A/3A Charger. The current battery arrangement is a mono block setup with 6 heats shrink packs and each pack contains 6 batteries. Each battery consists of 3 cells.

1. Battery arrangement	Monoblock (18 x 2 x 3)
2. Configuration	3 cells per battery 6 batteries per pack 6 packs per charger
3. Battery Cell Specification	Voltage 36Volt Float Voltage 42.3Volt Cyclic Voltage 44.1Volt Rating 10 Ah
4. Battery Specification	Volt 6 Volt Rating 5 Ah Power 7250W
5. Battery pack specification	Rating 10 Ah Voltage 124,3Volts Charging Current 3Amp
6. Charging system	Aztec Electronics, Type TAYR, 110/220V, 4A/3A
7. Space for battery pack	Width 380mm, Height 350mm, Depth 300mm

Quote: 8/3/228

## ADDENDUM B

### RECHARGEABLE BATTERIES FOR OTK SUBSTATION

The batteries should be compatible for use with the existing charging equipment.

#### Charging system specification:

STATIC POWER	
INPUT	OUTPUT
110/220V	32V
2A	3A
1 PHASE	LOAD: 25 N.C.
50HZ	DUTY: C
TYPE: IV 0323	SERIAL NO: 85/1033

The current battery arrangement is: 25 batteries of 1.2V and 10Ah

#### The batteries to be supplied must be:

1. Battery Model: SAFT KPZ 10
2. Battery type: Nickel Cadmium
3. Battery arrangement: 25 batteries series connected
4. Battery Specification: Voltage 1.2Volt  
Rating 10Ah
5. Warranty: 12 months
6. Space for battery pack: Width 550mm, Height 580mm, Depth 230mm

Quote: 8/3/228

## ADDENDUM C

### SPECIFICATION FOR PATENT PROTECTED KEY CONTROL LOCK SYSTEM

**NB: THE SELECTED SERVICE PROVIDER SHALL BE REQUIRED TO PROVIDE ACCEPTABLE SAMPLES BEFORE THE ORDER WILL BE FINAL**

- The key and keyway system offered must be patented and restricted for exclusive use by the municipality by means of being registered directly with the lock manufacturer.
- Keys may only be cut by the manufacturer with the key blanks not being available commercially.
- Padlock cylinders must have tight tolerance so as to eliminate key interchange
- Padlock cylinders must be inter changeable for ease of re-coring padlocks
- Padlocks and keys must be supplied separately to guarantee key security
- Padlocks and keys must be engraved and where required be colour coded
- PADLOCKS MUST RETAIN KEY IN THE OPEN POSITION

#### NETWORK LV & MV LOCKS (6835)

- Padlock body            Aluminium body
- Shackle                 Stainless steel
- Height                  50mm
- Width                    40mm
- Thickness               20mm
- Finish                    Powder coated Various colours
- Shackle dia             6 mm
- Shackle Length        38 mm to 42mm
- Shackle Width         20 mm
- Locking Mechanism    Dual stainless steel ball mechanism
- Shackle Springs        Nickel coated 304-grade stainless steel (din 17224)
- Mechanism              Six pin tumbler cylinder type with restricted keyway
- Barrel                    Removable interchangeable core for ease of rekey
- Driver Springs         Phosphor bronze
- Identification         Engraved-Trademark, part number
- Keyed alike             The LV locks must be keyed alike and the MV locks must be keyed alike

Quote: 8/3/228



#### STAFF LOCK-OUT LOCKS (6835)

- Padlock body - Aluminium body
  - Shackle - Stainless steel
  - Height - 50mm
  - Width - 40mm
  - Thickness- 20mm
  - Finish - Powder coated Various colours
  - Shackle dia - 6 mm
  - Shackle Length - 38 mm to 42mm
  - Shackle Width - 20 mm
  - Locking Mechanism - Dual stainless steel ball mechanism
  - Shackle Springs - Nickel coated 304-grade stainless steel (din 17224)
  - Mechanism - Six pin tumbler cylinder type with restricted keyway
  - Barrel - Removable interchangeable core for ease of rekey
  - Driver Springs- Phosphor bronze
  - Identification - Engraved- Staff identification.
  - Keyed alike- The locks for each staff member must be keyed alike
- SUBSTATION LOCKS & HASP (SEE DRAWING A - 6271 lock plus 770 hasp)

#### LOCK:

- Padlock body - Chrome plated, reinforced Die Cast
- Dimension - Round 73mm (to fit hasp bracket)
- Shackle dia - 10mm
- Shackle - Shrouded and hidden shackle of Hardened steel and Boron alloy
- Locking Mechanism - 5 pin tumbler cylinder type with restricted keyway
- Barrel - Removable interchangeable core for ease of rekey
- Keyed alike- Must be keyed the same as the MV locks

#### HASP: (SEE DRAWING A - 6271 lock plus 770 hasp)

- Body- Solid steel & chrome plated
- Dimension - 230mm Wide X 114mm Long
- Mechanism - Shrouded protection to limit access to lock

Quote: 8/3/228

**SAFETY LOCK OUT HASPS (SEE DRAWING B)**

- Material - Aluminium with bright coloured vinyl coating
- Colour- Red vinyl
- Mechanism- Traditional scissor action
- Access points-Provision for 6 locks

**LOCK OUT TAGS (SEE DRAWING C)**

- Material - PVC
- Colour- White, red and black
- Message- 4 languages “DANGER” and “DO NOT OPERATE-EQUIPMENT LOCKED OUT  
BY .....
- Attachment- Provision to attach tag with lock shackle with 6mm diameter.

**NB: THE SELECTED SERVICE PROVIDER SHALL BE REQUIRED TO PROVIDE ACCEPTABLE SAMPLES BEFORE THE ORDER WILL BE FINAL**

**QUANTITIES**

No	Description	Colour	Lock engraving	Qty
1	Network locks LV	Blue	Yes	300
2	Network locks MV	Yellow	Yellow	50
3	Staff lock-out locks	Red	Durie	10
4	Staff lock-out locks	Orange	O'Connell	10
5	Staff lock-out locks	Black	Hough	10
6	Staff lock-out locks	Green	Segafa	10
7	Staff lock-out locks	Any colour not used yet	Contractor	10
8	Substation Locks & Hasp	None	None	3
9	Safety Lock Out Hasp	Red	None	50
10	Lock Out Tags	NA	None	70

Quote: 8/3/228

**DRAWING A**

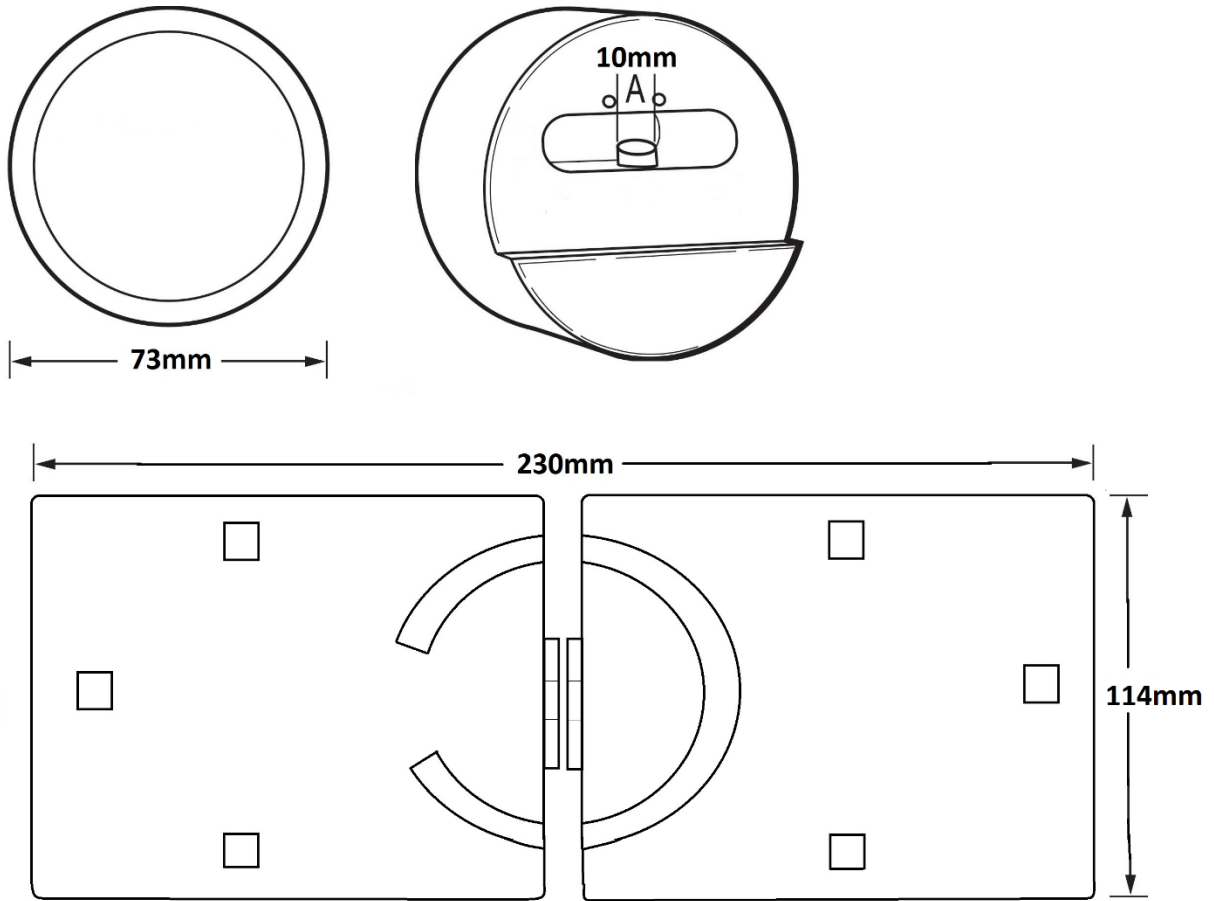

**DRAWING B**



DRAWING C



**PRICING SCHEDULE: SUPPLY AND DELIVERY OF ELECTRICAL AND RELATED MAINTENANCE MATERIAL (8/3/228)**

**Conditions:**

- All prices quoted should be VAT inclusive (for Vat vendors)
- Prices should be valid for a 90 day period
- If the pricing schedule is not signed the quotation will not be considered

Name of Bidder: \_\_\_\_\_

Contact Person: \_\_\_\_\_

Tel / Cell No: \_\_\_\_\_

Email Address: \_\_\_\_\_

Business Address: \_\_\_\_\_

No	DESCRIPTION	UNIT	QTY	RATE (R)	AMOUNT (R)
1	Batteries, rechargeable, for substation as specified in Annexure A	Sum	1		
2	Batteries, rechargeable, for substation as specified in Annexure B	Sum	1		
3	Keyed alike locks as specified in Annexure C	Sum	1		
4	Insulation oil for transformers. SABS 555. In 20liter drums or cans	No	10		
5	Droppers, T-type, Steel, 1250mm	No	300		
6	Cable Joint, Heat shrink, Inline, including Earthing Modules for: 70mm <sup>2</sup> , 3 Core, 11KV, PILC, PVC, Steel Wire Armed Cable.	No	4		
7	Termination, Heat shrink, Outdoor, including Earthing Modules for: 70mm <sup>2</sup> , 3 Core, 11KV, PILC, PVC, Steel Wire Armoured Cable.	No	4		
8	Boot, Heat shrink, Right angle, for 70mm <sup>2</sup> x 3-Core x 11kv PILC Cable	Sets of 3	6		
9	Cable Joint, resin cast, 3M 91A2 (for 25mm <sup>2</sup> x 4 core armoured cable, PVC, SWA,PVC)	No	4		
10	Cable Joint, resin cast, 3M 91A3(for 50mm <sup>2</sup> x 4 core armoured cable, PVC, SWA, PVC)	No	2		
11	Cable Joint, resin cast, 3M 91A4(for 95mm <sup>2</sup> x 4 core armoured cable, PVC, SWA, PVC)	No	2		
12	Cable Joint, resin cast, 3M 91A5(for 150mm <sup>2</sup> x 4 core armoured cable, PVC, SWA, PVC)	No	2		
13	Self-amalgamating insulation tape, 19mm x 9meter	No	10		
14	Electrical insulation putty-tape, thickness 3.175mm, 38mm wide and 1.5meter long	No	9		
15	Wheel barrow, Heavy Duty, SABS approved, steel, for construction	No	3		
16	Shovel, SABS, steel shaft	No	3		

17	Pick, 3kg, (keel pickaxe)	No	3		
18	Pick Handle, PVC	No	3		
19	Rakes, steel, with steel shaft	No	3		
20	Cable sleeve, 110mmØ, PVC	Meter	60		
21	Insulation tape, PVC, Nitto type: 5 x red, 5 x white, 5 x blue, 5 x black	No	20		
22	MC Circuit breaker, SABS, 1000A, 415Volt, 65kA, 3 phase, Thermal & Magnetic, complete with bus bars sections in supply and load side with two holes for connections per bus bar. (similar to Cbi N65D)	No	1		
23	Cable, flexible, 95mm <sup>2</sup> , annealed stranded copper, PVC insulated, 600v/1000V, 70°C, according to SANS 1507-3	Meter	15		
24	Cable ties, T50R, black(packs of 100)	pack	20		
25	Cable ties, T50I, black (packs of 100)	pack	20		
26	"Q" Clamp 26	No	10		
27	"Q" Clamp 32	No	10		
28	"Q" Clamp 40	No	10		
29	"Q" Clamp 46	No	10		
30	"Q" Clamp 52	No	10		
31	Rawl Bolts/Anchor Bolts, 6mmØ X 60mm	No	20		
32	Ferrules 16mm <sup>2</sup>	No	100		
33	Ferrules 35mm <sup>2</sup>	No	100		
34	Ferrules 50mm <sup>2</sup>	No	100		
35	Ferrules 70mm <sup>2</sup>	No	100		
36	Ferrules 95mm <sup>2</sup>	No	100		
37	Lugs 95mm <sup>2</sup> x 12mmØ	No	100		
38	Lugs 16mm <sup>2</sup> x 8mmØ	No	100		
39	Lugs 35mm <sup>2</sup> x 10mmØ	No	100		
40	Lugs 50mm <sup>2</sup> x 10mmØ	No	100		
41	Lugs 70mm <sup>2</sup> x 12mmØ	No	100		
42	Lugs 95mm <sup>2</sup> x 12mmØ	No	100		

	<b>SUB TOTAL</b>	
	<b>VAT</b>	
	<b>TOTAL (TO BE CARRIED TO THE FORM OF OFFER)</b>	

**ESTIMATED DELIVERY PERIOD (DAYS):** \_\_\_\_\_

\_\_\_\_\_  
**SIGNATURE**

\_\_\_\_\_  
**DATE**

**DECLARATION OF INTEREST**

- 1. No bid will be accepted from persons in the service of the state<sup>1</sup>.
- 2. Any person, having a kinship with persons in the service of the state, including a blood relationship, may make an offer or offers in terms of this invitation to bid. In view of possible allegations of favouritism, should the resulting bid, or part thereof, be awarded to persons connected with or related to persons in service of the state, it is required that the bidder or their authorised representative declare their position in relation to the evaluating/adjudicating authority and/or take an oath declaring his/her interest.

**3. In order to give effect to the above, the following questionnaire must be completed and submitted with the bid. Also select the applicable answers**

- 3.1 Full Name of bidder or his or her representative: .....
- .....
- 3.2 Identity Number: .....
- 3.3 Position occupied in the Company (director, trustee, shareholder<sup>2</sup>).....
- .....
- 3.4 Company Registration Number: .....
- 3.5 Tax Reference Number: .....
- 3.6 VAT Registration Number: .....
- 3.7 The names of all directors / trustees / shareholders members, their individual identity numbers and state employee numbers must be indicated in paragraph 4 below.

3.8 Are you presently in the service of the state\* YES  / NO

3.8.1 If yes, furnish particulars.

.....  
.....

<sup>1</sup>MSCM Regulations: "in the service of the state" means to be –

- (a) a member of –
  - (i) any municipal council;
  - (ii) any provincial legislature; or
  - (iii) the national Assembly or the national Council of provinces;
- (b) a member of the board of directors of any municipal entity;
- (c) an official of any municipality or municipal entity;
- (d) an employee of any national or provincial department, national or provincial public entity or constitutional institution within the meaning of the Public Finance Management Act, 1999 (Act No.1 of 1999);
- (e) a member of the accounting authority of any national or provincial public entity; or
- (f) an employee of Parliament or a provincial legislature.

<sup>2</sup> Shareholder" means a person who owns shares in the company and is actively involved in the management of the company or business and exercises control over the company



3.9 Have you been in the service of the state for the past twelve months? YES  / NO

3.9.1 If yes, furnish particulars

.....  
.....

3.10 Do you, have any relationship (family, friend, other) with person in the service of the state and who may be involved with the evaluation and or adjudication of this bid? YES  / NO

3.10.1 If yes, furnish particulars

.....  
.....

3.11 Are you, aware of any relationship (family, friend, other) between bidder and any persons in the service of the state who may be involved with the evaluation and adjudication of this bid? YES  / NO

3.11.1 If yes, furnish particulars

.....  
.....

3.12 Are any of the company's directors, managers, principle shareholders or stakeholders in service of the state? YES  / NO

3.12.1 If yes, furnish particulars

.....  
.....

3.13 Are any spouse, child or parent of the company's directors, trustees, managers, principle shareholders or stakeholders in service of the state? YES  / NO

3.13.1 If yes, furnish particulars

.....  
.....

3.14 Do you or any of the directors, trustees, managers, principle shareholders, or stakeholders of this company have any interest in any other companies or business whether or not they are bidding for this contract? YES  / NO

3.14.1 If yes furnish particulars:

.....  
.....

4. Full details of directors / trustees / members / shareholders.

Full Name	Identity Number	Employee Number

**CERTIFICATION**

**I, THE UNDERSIGNED**

**(NAME)** .....

**CERTIFY THAT THE INFORMATION FURNISHED ON THIS DECLARATION FORM IS CORRECT.**

I ACCEPT THAT THE STATE MAY ACT AGAINST ME SHOULD THIS DECLARATION PROVE TO BE FALSE.

.....

Signature

.....

Date

.....

Capacity

.....

Name of Bidder

**PREFERENCING SCHEDULE (FOR DIRECT PREFERENCES)**

**PREFERENCE POINTS CLAIM FORM IN TERMS OF THE PREFERENTIAL PROCUREMENT REGULATIONS 2001**

**PURCHASES**

This preference form must form part of all bids invited. It contains general information and serves as a claim form for Broad-Based Economic Empowerment (B-BBEE) Status Level of Contribution.

**NB: BEFORE COMPLETING THIS FORM, BIDDERS MUST STUDY THE GENERAL CONDITIONS, DEFINITIONS AND DIRECTIVES APPLICABLE IN RESPECT OF B-BBEE, AS PRESCRIBED IN THE PREFERENTIAL PROCUREMENT REGULATIONS, 2011.**

**1. GENERAL CONDITIONS**

1.1 The following preference point systems are applicable to all bids:

- the 80/20 system for requirements with a Rand value equal or below R1000 000

1.2 The value of this bid is estimated not to exceed R 1 000 000, and therefore the 80/20 system shall be applicable.

1.3 Preference points for this bid shall be awarded for:

- (a) Price; and
- (b) B-BBEE Status Level of Contribution

1.3.1 The maximum points for this bid are allocated as follows:

	<b>POINTS</b>
<b>1.3.1.1 PRICE</b>	<b>80</b>
<b>1.3.1.2 B-BBEE STATUS LEVEL OF CONTRIBUTION</b>	<b>20</b>
<b>Total points for Price and B-BBEE must not exceed</b>	<b>100</b>

**Separate Preference Points Claim Forms will be used for the promotion of the specific goals for which points have been allocated in paragraph 1.3.1.2 (b) above.**

1.4 Failure on the part of a bidder to fill in and/or to sign this form and submit a B-BBEE Verification Certificate from a Verification Agency accredited by the South African Accreditation System (SANAS) or a Registered Auditor approved by the Independent Regulatory Board of Auditors (IRBA) or an Accounting Officer as contemplated in the Close Corporation Act (CCA) together with the bid, will be interpreted to mean that preference points for B-BBEE status level of contribution are not claimed.

1.5. The purchaser reserves the right to require of a bidder, either before a bid is adjudicated or at any time subsequently, to substantiate any claim in regard to preferences, in any manner required by the purchaser.

## 2. DEFINITIONS

2.1 “**all applicable taxes**” includes value-added tax, pay as you earn, income tax, unemployment insurance fund contributions and skills development levies;

2.2 “**B-BBEE**” means broad-based black economic empowerment as defined in section 1 of the Broad -Based Black Economic Empowerment Act;

2.3 “**B-BBEE status level of contributor**” means the B-BBEE status received by a measured entity based on its overall performance using the relevant scorecard contained in the Codes of Good Practice on Black Economic Empowerment, issued in terms of section 9(1) of the Broad-Based Black Economic Empowerment Act;

2.4 “**bid**” means a written offer in a prescribed or stipulated form in response to an invitation by an organ of state for the provision of services, works or goods, through price quotations, advertised competitive bidding processes or proposals;

2.5 “**Broad-Based Black Economic Empowerment Act**” means the Broad-Based Black Economic Empowerment Act, 2003 (Act No. 53 of 2003);

2.6 “**comparative price**” means the price after the factors of a non-firm price and all unconditional discounts that can be utilized have been taken into consideration;

2.7 “**consortium or joint venture**” means an association of persons for the purpose of combining their expertise, property, capital, efforts, skill and knowledge in an activity for the execution of a contract;

2.8 “**contract**” means the agreement that results from the acceptance of a bid by an organ of state;

2.9 “**EME**” means any enterprise with an annual total revenue of R5 million or less.

2.10 “**Firm price**” means the price that is only subject to adjustments in accordance with the actual increase or decrease resulting from the change, imposition, or abolition of customs or excise duty and any other duty, levy, or tax, which, in terms of the law or regulation, is binding on the contractor and demonstrably has an influence on the price of any supplies, or the rendering costs of any service, for the execution of the contract;

2.11 “**functionality**” means the measurement according to predetermined norms, as set out in the bid documents, of a service or commodity that is designed to be practical and useful, working or operating, taking into account, among other factors, the quality, reliability, viability and durability of a service and the technical capacity and ability of a bidder;

2.12 “**non-firm prices**” means all prices other than “firm” prices;

2.13 “**person**” includes a juristic person;

2.14 “**rand value**” means the total estimated value of a contract in South African currency, calculated at the time of bid invitations, and includes all applicable taxes and excise duties;

- 2.15 **“sub-contract”** means the primary contractor’s assigning, leasing, making out work to, or employing, another person to support such primary contractor in the execution of part of a project in terms of the contract;
- 2.16 **“total revenue”** bears the same meaning assigned to this expression in the Codes of Good Practice on Black Economic Empowerment, issued in terms of section 9(1) of the Broad-Based Black Economic Empowerment Act and promulgated in the *Government Gazette* on 9 February 2007;
- 2.17 **“trust”** means the arrangement through which the property of one person is made over or bequeathed to a trustee to administer such property for the benefit of another person; and
- 2.18 **“trustee”** means any person, including the founder of a trust, to whom property is bequeathed in order for such property to be administered for the benefit of another person.

### **3. ADJUDICATION USING A POINT SYSTEM**

- 3.1 The bidder obtaining the highest number of total points will be awarded the contract.
- 3.2 Preference points shall be calculated after prices have been brought to a comparative basis taking into account all factors of non-firm prices and all unconditional discounts;
- 3.3 Points scored must be rounded off to the nearest 2 decimal places.
- 3.4 In the event that two or more bids have scored equal total points, the successful bid must be the one scoring the highest number of preference points for B-BBEE.
- 3.5 However, when functionality is part of the evaluation process and two or more bids have scored equal points including equal preference points for B-BBEE, the successful bid must be the one scoring the highest score for functionality.
- 3.6 Should two or more bids be equal in all respects, the award shall be decided by the drawing of lots.

### **4. POINTS AWARDED FOR PRICE**

#### **4.1 THE 80/20 PREFERENCE POINT SYSTEMS**

A maximum of 80 points is allocated for price on the following basis:

**80/20**

$$P_s = 80 \left( 1 - \frac{P_t - P_{\min}}{P_{\min}} \right)$$

Where

- $P_s$  = Points scored for comparative price of bid under consideration
- $P_t$  = Comparative price of bid under consideration
- $P_{\min}$  = Comparative price of lowest acceptable bid

## 5. Points awarded for B-BBEE Status Level of Contribution

- 5.1 In terms of Regulation 5 (2) and 6 (2) of the Preferential Procurement Regulations, preference points must be awarded to a bidder for attaining the B-BBEE status level of contribution in accordance with the table below:

<b>B-BBEE Status Level of Contributor</b>	<b>Number of points (80/20 system)</b>
1	20
2	18
3	16
4	12
5	8
6	6
7	4
8	2
Non-compliant contributor	0

- 5.2 Bidders who qualify as EMEs in terms of the B-BBEE Act must submit a certificate issued by an Accounting Officer as contemplated in the CCA or a Verification Agency accredited by SANAS or a Registered Auditor. Registered auditors do not need to meet the prerequisite for IRBA's approval for the purpose of conducting verification and issuing EMEs with B-BBEE Status Level Certificates.
- 5.3 Bidders other than EMEs must submit their original and valid B-BBEE status level verification certificate or a certified copy thereof, substantiating their B-BBEE rating issued by a Registered Auditor approved by IRBA or a Verification Agency accredited by SANAS.
- 5.4 A trust, consortium or joint venture, will qualify for points for their B-BBEE status level as a legal entity, provided that the entity submits their B-BBEE status level certificate.
- 5.5 A trust, consortium or joint venture will qualify for points for their B-BBEE status level as an unincorporated entity, provided that the entity submits their consolidated B-BBEE scorecard as if they were a group structure and that such a consolidated B-BBEE scorecard is prepared for every separate bid.
- 5.6 Tertiary institutions and public entities will be required to submit their B-BBEE status level certificates in terms of the specialized scorecard contained in the B-BBEE Codes of Good Practice.
- 5.7 A person will not be awarded points for B-BBEE status level if it is indicated in the bid documents that such a bidder intends sub-contracting more than 25% of the value of the contract to any other

enterprise that does not qualify for at least the points that such a bidder qualifies for, unless the intended sub-contractor is an EME that has the capability and ability to execute the sub-contract.

5.8 A person awarded a contract may not sub-contract more than 25% of the value of the contract to any other enterprise that does not have an equal or higher B-BBEE status level than the person concerned, unless the contract is sub-contracted to an EME that has the capability and ability to execute the sub-contract.

**6. BID DECLARATION**

6.1 Bidders who claim points in respect of B-BBEE Status Level of Contribution must complete the following:

**7. B-BBEE STATUS LEVEL OF CONTRIBUTION CLAIMED IN TERMS OF PARAGRAPHS 1.3.1.2 AND 5.1**

7.1 B-BBEE Status Level of Contribution: ..... = .....(maximum of 20 points)

(Points claimed in respect of paragraph 7.1 must be in accordance with the table reflected in paragraph 5.1 and must be substantiated by means of a B-BBEE certificate issued by a Verification Agency accredited by SANAS or a Registered Auditor approved by IRBA or an Accounting Officer as contemplated in the CCA).

**8 SUB-CONTRACTING**

8.1 Will any portion of the contract be sub-contracted? YES  / NO

8.1.1 If yes, indicate:

- (i) what percentage of the contract will be subcontracted? .....%
- (ii) the name of the sub-contractor? .....
- (iii) the B-BBEE status level of the sub-contractor? .....
- (iv) whether the sub-contractor is an EME? YES  / NO

**9 DECLARATION WITH REGARD TO COMPANY/FIRM**

9.1 Name of company/firm :.....

9.2 VAT registration number :.....

9.3 Company registration number :.....

9.4 TYPE OF COMPANY/ FIRM

- Partnership/Joint Venture / Consortium
- One person business/sole propriety
- Close corporation
- Company
- (Pty) Limited

[TICK APPLICABLE BOX]

9.5 DESCRIBE PRINCIPAL BUSINESS ACTIVITIES

.....

.....

.....

9.6 COMPANY CLASSIFICATION

- Manufacturer
- Supplier
- Professional service provider
- Other service providers, e.g. transporter, etc.

[TICK APPLICABLE BOX]

9.7 Total number of years the company/firm has been in business? .....

9.8 I/we, the undersigned, who is / are duly authorised to do so on behalf of the company/firm, certify that the points claimed, based on the B-BBE status level of contribution indicated in paragraph 7 of the foregoing certificate, qualifies the company/ firm for the preference(s) shown and I / we acknowledge that:

- (i) The information furnished is true and correct;
- (ii) The preference points claimed are in accordance with the General Conditions as indicated in paragraph 1 of this form.



(iii) In the event of a contract being awarded as a result of points claimed as shown in paragraph 7, the contractor may be required to furnish documentary proof to the satisfaction of the purchaser that the claims are correct;

(iv) If the B-BBEE status level of contribution has been claimed or obtained on a fraudulent basis or any of the conditions of contract have not been fulfilled, the purchaser may, in addition to any other remedy it may have –

- (a) Disqualify the person from the bidding process;
- (b) recover costs, losses or damages it has incurred or suffered as a result of that person's conduct;
- (c) cancel the contract and claim any damages which it has suffered as a result of having to make less favourable arrangements due to such cancellation;
- (d) restrict the bidder or contractor, its shareholders and directors, or only the shareholders and directors who acted on a fraudulent basis, from obtaining business from any organ of state for a period not exceeding 10 years, after the audi alteram partem (hear the other side) rule has been applied; and
- (e) forward the matter for criminal prosecution

**WITNESSES:**

1. ....

2. ....

DATE:.....

.....  SIGNATURE(S) OF BIDDER(S)
--

ADDRESS:.....

.....

.....

.....

## DECLARATION OF BIDDER'S PAST SUPPLY CHAIN MANAGEMENT PRACTICES

- 1 This Municipal Bidding Document must form part of all bids invited.
- 2 It serves as a declaration to be used by municipalities and municipal entities in ensuring that when goods and services are being procured, all reasonable steps are taken to combat the abuse of the supply chain management system.
- 3 The bid of any bidder may be rejected if that bidder, or any of its directors have:
  - a. abused the municipality's / municipal entity's supply chain management system or committed any improper conduct in relation to such system;
  - b. been convicted for fraud or corruption during the past five years;
  - c. willfully neglected, reneged on or failed to comply with any government, municipal or other public sector contract during the past five years; or
  - d. been listed in the Register for Tender Defaulters in terms of section 29 of the Prevention and Combating of Corrupt Activities Act (No 12 of 2004).
- 4 **In order to give effect to the above, the following questionnaire must be completed and submitted with the bid.**

Item	Question	Yes	No
4.1	<p>Is the bidder or any of its directors listed on the National Treasury's Database of Restricted Suppliers as companies or persons prohibited from doing business with the public sector?</p> <p>(Companies or persons who are listed on this Database were informed in writing of this restriction by the Accounting Officer/Authority of the institution that imposed the restriction after the <i>audi alteram partem</i> rule was applied).</p> <p><b>The Database of Restricted Suppliers now resides on the National Treasury's website(<a href="http://www.treasury.gov.za">www.treasury.gov.za</a>) and can be accessed by clicking on its link at the bottom of the home page.</b></p>	Yes <input type="checkbox"/>	No <input type="checkbox"/>
4.1.1	If so, furnish particulars:		
4.2	<p>Is the bidder or any of its directors listed on the Register for Tender Defaulters in terms of section 29 of the Prevention and Combating of Corrupt Activities Act (No 12 of 2004)?</p> <p><b>The Register for Tender Defaulters can be accessed on the National Treasury's website (<a href="http://www.treasury.gov.za">www.treasury.gov.za</a>) by clicking on its link at the bottom of the home page.</b></p>	Yes <input type="checkbox"/>	No <input type="checkbox"/>
4.2.1	If so, furnish particulars:		

4.3	Was the bidder or any of its directors convicted by a court of law (including a court of law outside the Republic of South Africa) for fraud or corruption during the past five years?	Yes <input type="checkbox"/>	No <input type="checkbox"/>
4.3.1	If so, furnish particulars:		
4.4	Does the bidder or any of its directors owe any municipal rates and taxes or municipal charges to the municipality / municipal entity, or to any other municipality / municipal entity, that is in arrears for more than three months?	Yes <input type="checkbox"/>	No <input type="checkbox"/>
4.4.1	If so, furnish particulars:		
4.5	Was any contract between the bidder and the municipality / municipal entity or any other organ of state terminated during the past five years on account of failure to perform on or comply with the contract?	Yes <input type="checkbox"/>	No <input type="checkbox"/>
4.7.1	If so, furnish particulars:		

**CERTIFICATION**

**I, THE UNDERSIGNED (FULL NAME) .....  
CERTIFY THAT THE INFORMATION FURNISHED ON THIS  
DECLARATION FORM TRUE AND CORRECT.**

**I ACCEPT THAT, IN ADDITION TO CANCELLATION OF A CONTRACT, ACTION  
MAY BE TAKEN AGAINST ME SHOULD THIS DECLARATION PROVE TO BE  
FALSE.**

.....  
**Signature**

.....  
**Date**

.....  
**Position**

.....  
**Name of Bidder**

Js367bW

**CERTIFICATE OF INDEPENDENT BID DETERMINATION**

- 1 This Municipal Bidding Document (MBD) must form part of all bids<sup>1</sup> invited.
  
- 2 Section 4 (1) (b) (iii) of the Competition Act No. 89 of 1998, as amended, prohibits an agreement between, or concerted practice by, firms, or a decision by an association of firms, if it is between parties in a horizontal relationship and if it involves collusive bidding (or bid rigging).<sup>2</sup> Collusive bidding is a *pe se* prohibition meaning that it cannot be justified under any grounds.
  
- 3 Municipal Supply Regulation 38 (1) prescribes that a supply chain management policy must provide measures for the combating of abuse of the supply chain management system, and must enable the accounting officer, among others, to:
  - a. take all reasonable steps to prevent such abuse;
  - b. reject the bid of any bidder if that bidder or any of its directors has abused the supply chain management system of the municipality or municipal entity or has committed any improper conduct in relation to such system; and
  - c. cancel a contract awarded to a person if the person committed any corrupt or fraudulent act during the bidding process or the execution of the contract.
  
- 4 This MBD serves as a certificate of declaration that would be used by institutions to ensure that, when bids are considered, reasonable steps are taken to prevent any form of bid-rigging.
  
- 5 In order to give effect to the above, the attached Certificate of Bid Determination (MBD 9) must be completed and submitted with the bid:

<sup>1</sup> Includes price quotations, advertised competitive bids, limited bids and proposals.

<sup>2</sup> Bid rigging (or collusive bidding) occurs when businesses, that would otherwise be expected to compete, secretly conspire to raise prices or lower the quality of goods and / or services for purchasers who wish to acquire goods and / or services through a bidding process. Bid rigging is, therefore, an agreement between competitors not to compete.

**CERTIFICATE OF INDEPENDENT BID DETERMINATION**

I, the undersigned, in submitting the accompanying bid:

\_\_\_\_\_  
(Bid Number and Description)

in response to the invitation for the bid made by:

\_\_\_\_\_  
(Name of Municipality / Municipal Entity)

do hereby make the following statements that I certify to be true and complete in every respect:

I certify, on behalf of: \_\_\_\_\_ that:  
(Name of Bidder)

1. I have read and I understand the contents of this Certificate;
2. I understand that the accompanying bid will be disqualified if this Certificate is found not to be true and complete in every respect;
3. I am authorized by the bidder to sign this Certificate, and to submit the accompanying bid, on behalf of the bidder;
4. Each person whose signature appears on the accompanying bid has been authorized by the bidder to determine the terms of, and to sign, the bid, on behalf of the bidder;
5. For the purposes of this Certificate and the accompanying bid, I understand that the word "competitor" shall include any individual or organization, other than the bidder, whether or not affiliated with the bidder, who:
  - (a) has been requested to submit a bid in response to this bid invitation;
  - (b) could potentially submit a bid in response to this bid invitation, based on their qualifications, abilities or experience; and
  - (c) provides the same goods and services as the bidder and/or is in the same line of business as the bidder

6. The bidder has arrived at the accompanying bid independently from, and without consultation, communication, agreement or arrangement with any competitor. However communication between partners in a joint venture or consortium<sup>3</sup> will not be construed as collusive bidding.
7. In particular, without limiting the generality of paragraphs 6 above, there has been no consultation, communication, agreement or arrangement with any competitor regarding:
  - (a) prices;
  - (b) geographical area where product or service will be rendered (market allocation)
  - (c) methods, factors or formulas used to calculate prices;
  - (d) the intention or decision to submit or not to submit, a bid;
  - (e) the submission of a bid which does not meet the specifications and conditions of the bid; or
  - (f) bidding with the intention not to win the bid.
8. In addition, there have been no consultations, communications, agreements or arrangements with any competitor regarding the quality, quantity, specifications and conditions or delivery particulars of the products or services to which this bid invitation relates.
9. The terms of the accompanying bid have not been, and will not be, disclosed by the bidder, directly or indirectly, to any competitor, prior to the date and time of the official bid opening or of the awarding of the contract.

<sup>3</sup> Joint venture or Consortium means an association of persons for the purpose of combining their expertise, property, capital, efforts, skill and knowledge in an activity for the execution of a contract.

10. I am aware that, in addition and without prejudice to any other remedy provided to combat any restrictive practices related to bids and contracts, bids that are suspicious will be reported to the Competition Commission for investigation and possible imposition of administrative penalties in terms of section 59 of the Competition Act No 89 of 1998 and or may be reported to the National Prosecuting Authority (NPA) for criminal investigation and or may be restricted from conducting business with the public sector for a period not exceeding ten (10) years in terms of the Prevention and Combating of Corrupt Activities Act No 12 of 2004 or any other applicable legislation.

.....  
Signature

.....  
Date

.....  
Position

.....  
Name of Bidder

Js9141

## **DECLARATION CERTIFICATE FOR LOCAL PRODUCTION AND CONTENT FOR DESIGNATED SECTORS**

This Municipal Bidding Document (MBD) must form part of all bids invited. It contains general information and serves as a declaration form for local content (local production and local content are used interchangeably).

Before completing this declaration, bidders must study the General Conditions, Definitions, Directives applicable in respect of Local Content as prescribed in the Preferential Procurement Regulations, 2011 and the South African Bureau of Standards (SABS) approved technical specification number SATS 1286:2011 (Edition 1) and the Guidance on the Calculation of Local Content together with the Local Content Declaration Templates [Annex C (Local Content Declaration: Summary Schedule), D (Imported Content Declaration: Supporting Schedule to Annex C) and E (Local Content Declaration: Supporting Schedule to Annex C)].

### **1. General Conditions**

- 1.1. Preferential Procurement Regulations, 2011 (Regulation 9) makes provision for the promotion of local production and content.
- 1.2. Regulation 9.(1) prescribes that in the case of designated sectors, where in the award of bids local production and content is of critical importance, such bids must be advertised with the specific bidding condition that only locally produced goods, services or works or locally manufactured goods, with a stipulated minimum threshold for local production and content will be considered.
- 1.3. Where necessary, for bids referred to in paragraph 1.2 above, a two stage bidding process may be followed, where the first stage involves a minimum threshold for local production and content and the second stage price and B-BBEE.
- 1.4. A person awarded a contract in relation to a designated sector, may not sub-contract in such a manner that the local production and content of the overall value of the contract is reduced to below the stipulated minimum threshold.
- 1.5. The local content (LC) expressed as a percentage of the bid price must be calculated in accordance with the SABS approved technical specification number SATS 1286: 2011 as follows:

$$LC = [1 - x / y] * 100$$

Where

x is the imported content in Rand

y is the bid price in Rand excluding value added tax (VAT)

Prices referred to in the determination of x must be converted to Rand (ZAR) by using the exchange rate published by the South African Reserve Bank (SARB) at 12:00 on the date of advertisement of the bid as required in paragraph 4.1 below.

**The SABS approved technical specification number SATS 1286:2011 is accessible on [http://www.thedti.gov.za/industrial development/ip.jsp](http://www.thedti.gov.za/industrial%20development/ip.jsp) at no cost.**



1.6. A bid may be disqualified if –

- (a) this Declaration Certificate and the Annex C (Local Content Declaration: Summary Schedule) are not submitted as part of the bid documentation; and
- (b) the bidder fails to declare that the Local Content Declaration Templates (Annex C, D and E) have been audited and certified as correct.

## 2. Definitions

2.1. **“bid”** includes written price quotations, advertised competitive bids or proposals;

2.2. **“bid price”** price offered by the bidder, excluding value added tax (VAT);

2.3. **“contract”** means the agreement that results from the acceptance of a bid by an organ of state;

2.4. **“designated sector”** means a sector, sub-sector or industry that has been designated by the Department of Trade and Industry in line with national development and industrial policies for local production, where only locally produced services, works or goods or locally manufactured goods meet the stipulated minimum threshold for local production and content;

2.5. **“duly sign”** means a Declaration Certificate for Local Content that has been signed by the Chief Financial Officer or other legally responsible person nominated in writing by the Chief Executive, or senior member / person with management responsibility (close corporation, partnership or individual).

2.6. **“imported content”** means that portion of the bid price represented by the cost of components, parts or materials which have been or are still to be imported (whether by the supplier or its subcontractors) and which costs are inclusive of the costs abroad (this includes labour and intellectual property costs), plus freight and other direct importation costs, such as landing costs, dock duties, import duty, sales duty or other similar tax or duty at the South African port of entry;

2.7. **“local content”** means that portion of the bid price which is not included in the imported content, provided that local manufacture does take place;

2.8. **“stipulated minimum threshold”** means that portion of local production and content as determined by the Department of Trade and Industry; and

2.9. **“sub-contract”** means the primary contractor’s assigning, leasing, making out work to, or employing another person to support such primary contractor in the execution of part of a project in terms of the contract.

## 3. The stipulated minimum threshold(s) for local production and content (refer to Annex A of SATS 1286:2011) for this bid is/are as follows:

<u>Description of services, works or goods</u>	<u>Stipulated minimum threshold</u>
_____	_____ %
_____	_____ %
_____	_____ %
_____	_____ %

4. Does any portion of the services, works or goods offered have any imported content?  
(Tick applicable box)

YES	<input type="checkbox"/>	NO	<input type="checkbox"/>
-----	--------------------------	----	--------------------------

- 4.1 If yes, the rate(s) of exchange to be used in this bid to calculate the local content as prescribed in paragraph 1.5 of the general conditions must be the rate(s) published by the SARB for the specific currency at 12:00 on the date of advertisement of the bid.

The relevant rates of exchange information is accessible on [www.reservebank.co.za](http://www.reservebank.co.za).

Indicate the rate(s) of exchange against the appropriate currency in the table below (refer to Annex A of SATS 1286:2011):

<b>Currency</b>	<b>Rates of exchange</b>
US Dollar	
Pound Sterling	
Euro	
Yen	
Other	

NB: Bidders must submit proof of the SARB rate (s) of exchange used.

5. Were the Local Content Declaration Templates (Annex C, D and E) audited and certified as correct?  
(Tick applicable box)

YES	<input type="checkbox"/>	NO	<input type="checkbox"/>
-----	--------------------------	----	--------------------------

- 5.1. If yes, provide the following particulars:

- (a) Full name of auditor: .....
- (b) Practice number: .....
- (c) Telephone and cell number: .....
- (d) Email address: .....

(Documentary proof regarding the declaration will, when required, be submitted to the satisfaction of the Accounting Officer / Accounting Authority)

6. Where, after the award of a bid, challenges are experienced in meeting the stipulated minimum threshold for local content the dti must be informed accordingly in order for the

dti to verify and in consultation with the Accounting Officer / Accounting Authority provide directives in this regard.

**LOCAL CONTENT DECLARATION**  
**(REFER TO ANNEX B OF SATS 1286:2011)**

**LOCAL CONTENT DECLARATION BY CHIEF FINANCIAL OFFICER OR OTHER LEGALLY RESPONSIBLE PERSON NOMINATED IN WRITING BY THE CHIEF EXECUTIVE OR SENIOR MEMBER/PERSON WITH MANAGEMENT RESPONSIBILITY (CLOSE CORPORATION, PARTNERSHIP OR INDIVIDUAL)**

**IN RESPECT OF BID NO.** .....

**ISSUED BY:** (Procurement Authority / Name of Municipality / Municipal Entity):

.....

NB

1 The obligation to complete, duly sign and submit this declaration cannot be transferred to an external authorized representative, auditor or any other third party acting on behalf of the bidder.

2 Guidance on the Calculation of Local Content together with Local Content Declaration Templates (Annex C, D and E) is accessible on <http://www.thedti.gov.za/industrialdevelopment/ip.jsp>. Bidders should first complete Declaration D. After completing Declaration D, bidders should complete Declaration E and then consolidate the information on Declaration C. **Declaration C should be submitted with the bid documentation at the closing date and time of the bid in order to substantiate the declaration made in paragraph (c) below.** Declarations D and E should be kept by the bidders for verification purposes for a period of at least 5 years. The successful bidder is required to continuously update Declarations C, D and E with the actual values for the duration of the contract.

I, the undersigned, ..... (full names),  
do hereby declare, in my capacity as .....  
of .....(name of bidder  
entity), the following:

(a) The facts contained herein are within my own personal knowledge.

(b) I have satisfied myself that

- (i) the goods/services/works to be delivered in terms of the above-specified bid comply with the minimum local content requirements as specified in the bid, and as measured in terms of SATS 1286:2011; and
- (ii) the declaration templates have been audited and certified to be correct.

(c) The local content percentages (%) indicated below has been calculated using the formula given in clause 3 of SATS 1286:2011, the rates of exchange indicated in paragraph 4.1 above and the information contained in Declaration D and E which has been consolidated in Declaration C;

Bid price, excluding VAT (y)	R
Imported content (x), as calculated in terms of SATS 1286:2011	R
Stipulated minimum threshold for local content (paragraph 3 above)	
Local content %, as calculated in terms of SATS 1286:2011	

**If the bid is for more than one product, the local content percentages for each product contained in Declaration C shall be used instead of the table above. The local content percentages for each product has been calculated using the formula given in clause 3 of SATS 1286:2011, the rates of exchange indicated in paragraph 4.1 above and the information contained in Declaration D and E.**

(d) I accept that the Procurement Authority / Municipality /Municipal Entity has the right to request that the local content be verified in terms of the requirements of SATS 1286:2011.

(e) I understand that the awarding of the bid is dependent on the accuracy of the information furnished in this application. I also understand that the submission of incorrect data, or data that are not verifiable as described in SATS 1286:2011, may result in the Procurement Authority / Municipal / Municipal Entity imposing any or all of the remedies as provided for in Regulation 13 of the Preferential Procurement Regulations, 2011 promulgated under the Preferential Policy Framework Act (PPPFA), 2000 (Act No. 5 of 2000).

**SIGNATURE:** \_\_\_\_\_

**DATE:** \_\_\_\_\_

**WITNESS No. 1** \_\_\_\_\_

**DATE:** \_\_\_\_\_

**WITNESS No. 2** \_\_\_\_\_

**DATE:** \_\_\_\_\_

## Annex C

## Local Content Declaration - Summary Schedule

Note: VAT to be excluded from all calculations

(C1) Tender No:

(C2) Tender Description:

(C3) Designated Product(s):

(C4) Tender Authority:

(C5) Tendering Entity Name:

(C6) Tender Exchange Rate:

Pula:

EU:

GBP:

(C7) Specified local content %:

Calculation of local content						Tender summary					
Tender item no's	List of Items	Tender price-each (excl VAT)	Exempted imported value	Tender value net of exempted imported content	Imported value	Local value	Local content % (per item)	Tender Qty	Total tender value	Total exempted imported content	Total imported content
(C8)	(C9)	(C10)	(C11)	(C12)	(C13)	(C14)	(C15)	(C16)	(C17)	(C18)	(C19)
(C20) Total tender value						R 0					
(C21) Total Exempt imported content						R 0					
(C22) Total Tender value net of exempt imported content						R 0					
(C23) Total Imported content						R 0					
(C24) Total local content						R 0					
(C25) Average local content % of tender											
Signature of tenderer from Annex B:											
Date:											